

Zeta Intrinsically Safe Programmable Heat Detector (ZIS-PHD)



Description

The ZIS-PHD heat (temperature) detector is designed to detect a fire hazard in rooms, where during the first phase of a fire a rapid rise of temperature may occur, or where temperature may exceed a defined danger level.

The ZIS-PHD is a universal heat detector, which can be programmed to operate as a fixed temperature or fixed/rate-of rise heat detector. It is also possible to change the class of these detectors adapting them to specific applications. The PN-EN 54-5 European standard allows a choice of one of the following classes of detector sensitivity: A1R, A1S, BR or BS.

The ZIS-PHD is a spark proof detector, due to which it can be used in explosion hazard areas. These detectors operate in Zeta manufactured fire alarm system detector lines behind a proper spark proof separator.

Dimensions (mm) & Weight (kg)

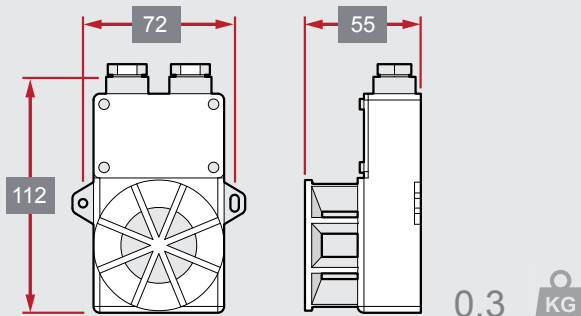

Technical Specification

Model	ZIS-PHD
Part No.	84-105
Voltage	17 ÷ 24 V
Quiescent current	< 100 µA
Alarm current by 20 V	20 mA
Class of the detector pursuant to PN-EN 54-5 standard	A1R, A1S, BR, BS
Static operating temp.	54 °C ÷ 65 °C (class A1) 69 °C ÷ 85 °C (class B)
Normal operating temp.	25 °C (class A1) 40 °C (class B)
Operation temp. range	from -25 °C up to +50 °C (class A1) from -25 °C up to +65 °C (class B)
Relative humidity	up to 95 % at 40 °C
Ingress protection	IP44
Colour	black
Dimensions	112 x 72 x 55 mm
Weight	0.3kg

Principles of Operation

The ZIS-PHD heat detector reacts to a rise of temperature occurring during an open fire. The detector operates as a fixed temperature detector after exceeding its preset operation threshold, per its given class, and as a rate-of-rise detector during a sudden rise of temperature. It is possible to programme it to operate only as a fixed temperature detector.

Changes in temperature in the detector's surroundings are controlled by its electronic unit with a measuring thermistor, which, after differentiating the said changes, transmits an appropriate alarm signal to the interoperating fire alarm control panel and initiates the LED diode in the detector.

The detectors are produced in an independent casing equipped with two cable glands through which detection line wires of the monitoring line are directly connected. The detectors do not require additional mounting bases. There is a free access (after removing the top from the detector casing) to contacts to enable connecting wires and jumpers allowing setting the class of the detector.

The ZIS-PHD detector casing is made of black plastic.

An additional optical alarm signal of a detector or a group of detectors in an event they are installed in a hard to reach space can be obtained by connecting the WZ-31 alarm indicator.

Additional Information

The TUN-38Ex detector has the ATEX certificate of the Central Mining Institute No. KDB 04ATEX190X and has been granted a spark proof feature - II 2G EEx ib IIC T6.